



GENUINE PARTS



INSTALLATION INSTRUCTIONS

1. DESCRIPTION: SIDE GUARD MOLDING

2. APPLICATION: QX80

3. PART NUMBER: F3870-1LA00

4. KIT CONTENTS:

Item	Qty.	Description	Part Number
(A)	1	FR SIDE GUARD MOLDING - LH	---
(B)	1	RR SIDE GUARD MOLDING - LH	---
(C)	1	FR SIDE GUARD MOLDING - RH	---
(D)	1	RR SIDE GUARD MOLDING - RH	---
(E)	1	TEMPLATE A LH	---
(F)	1	TEMPLATE B LH	---
(G)	1	TEMPLATE C LH	---
(H)	1	TEMPLATE A RH	---
(I)	1	TEMPLATE B RH	---
(J)	1	TEMPLATE C RH	---
(K)	1	INSTALLATION INSTRUCTIONS REPLACEMENT TEMPLATE	---

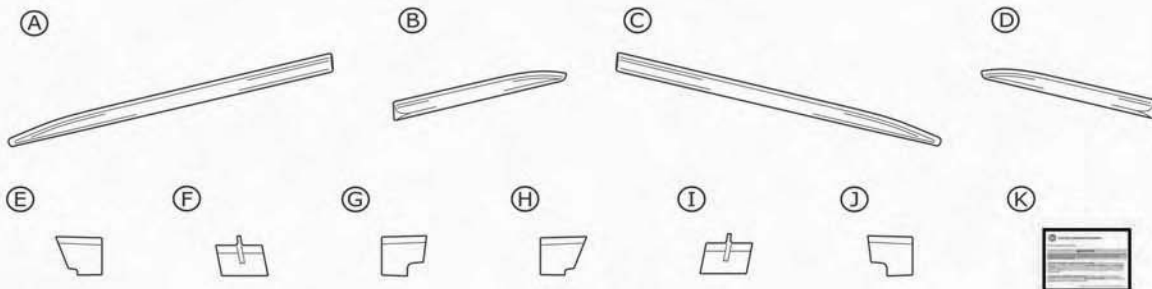

5. TOOLS REQUIRED:

- 100% Alcohol
- Masking tape
- Clean, lint-free wiping cloth

6. PRE-INSTALLATION CAUTIONS/NOTES:

NOTE

- These instructions are for the left side of the vehicle; the same procedure applies to the right side.

INSTALLATION INSTRUCTIONS - Side Guard Molding Kit

7. INSTALLATION PROCEDURE:

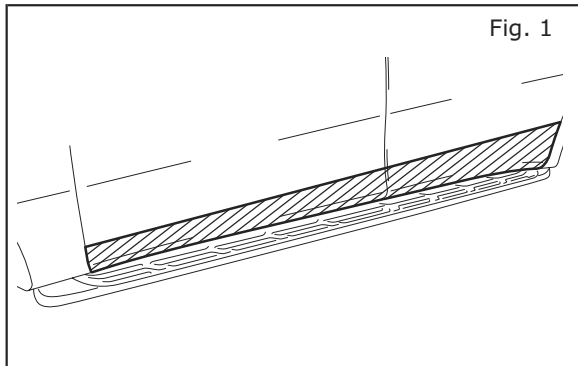

1. Side Guard Molding Installation preparations

- Decrease the hashed area indicated on the left with 100% alcohol.

* **Be careful not to touch this area while working.**

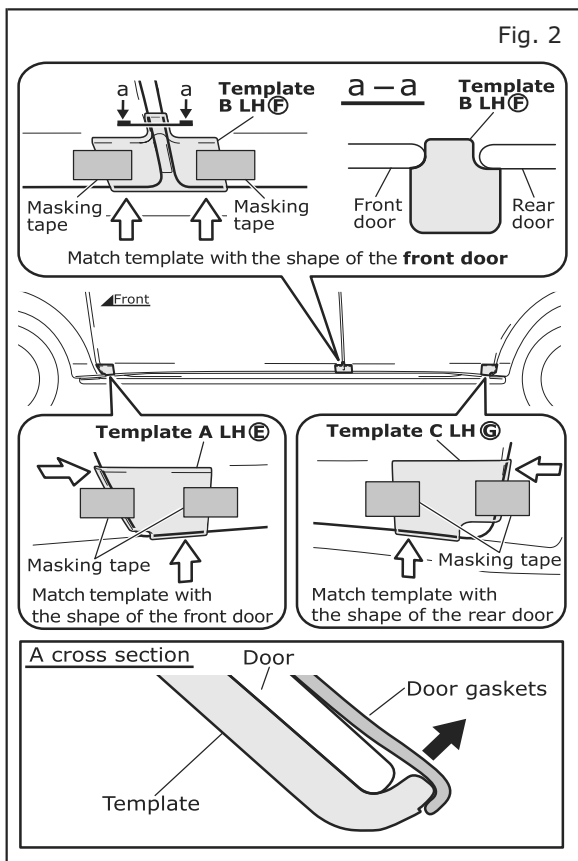

- While referring to the illustration Fig 2, use masking tape and attach **template A LH (E)** to the front door's front bottom edge, **template B LH (F)** to the front door's back bottom edge and **template C LH (G)** to the rear door's back bottom edge.

INSTALLATION INSTRUCTIONS - Side Guard Molding Kit

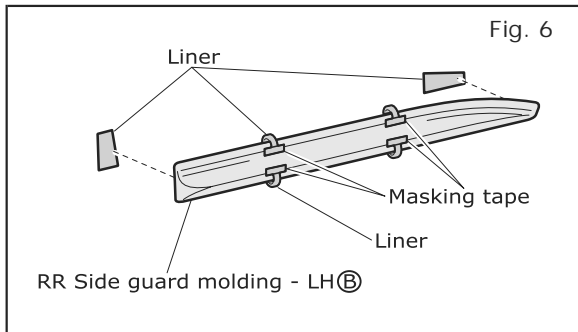
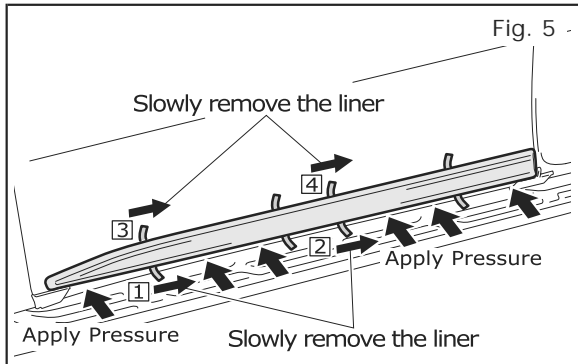
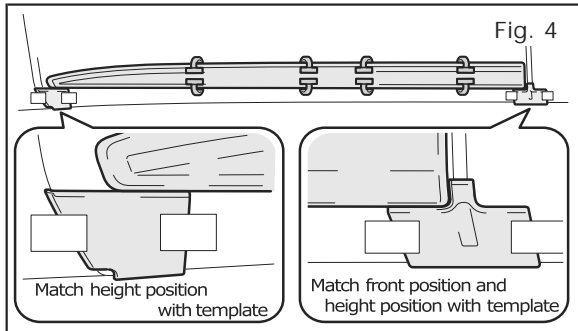
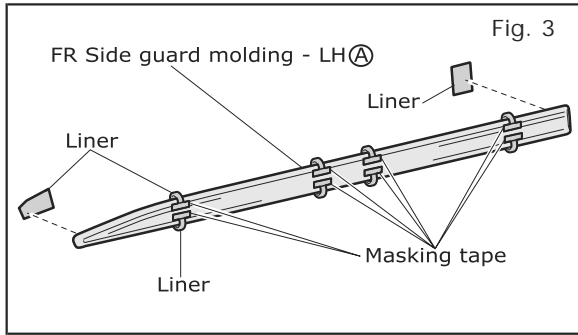

2. Install FR Side Guard Molding

- Peel back approximately 50mm of tape liner (8 pcs.) from double - sided tape on FR side guard molding - LH (A).
- Fold tape liner pull tabs onto the FR side guard molding - LH (A) surface and apply masking tape to ensure that the pull tabs are accessible. See Fig 3.
- Completely remove the two liners located at the front and rear of the FR side guard molding - LH (A). See Fig 3.
- Align the FR side guard molding - LH (A) to the templates as shown Fig 4.

- Completely remove the 8 liners in the order shown and apply at least 15lbs.(49N) of pressure to the molding. See Fig 5.

*** Apply at least 15lbs.(49N) or more of pressure to the taped area. Pressure that is less than 15lbs.(49N) may allow the tape to peel , creating gaps.**

3. Install RR Side Guard Molding

- Peel back approximately 50mm of tape liner (4 pcs.) from double - sided tape on RR side guard molding - LH (B).
- Fold tape liner pull tabs onto the RR side guard molding - LH (B) surface and apply masking tape to ensure that the pull tabs are accessible. See Fig 6.
- Completely remove the two liners located at the front and rear of the RR side guard molding - LH (B). See Fig 6.

INSTALLATION INSTRUCTIONS - Side Guard Molding Kit

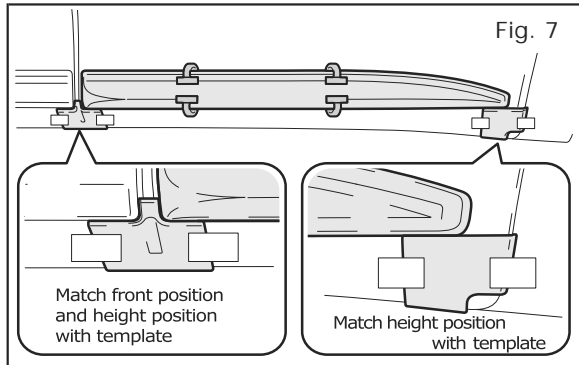

- d) Align the RR side guard molding - LH (B) to the templates as shown Fig 7.

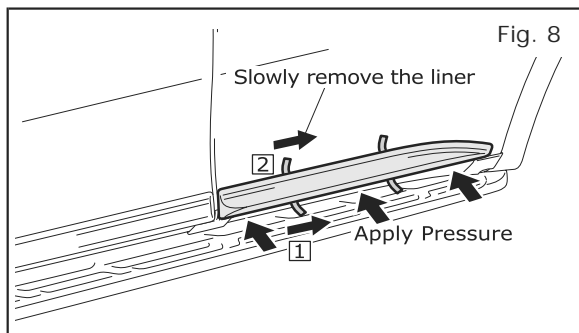

- e) Completely remove the 4 liners in the order shown and apply at least 15lbs.(49N) of pressure to the molding. See Fig 8.
- * **Apply at least 15lbs.(49N) or more of pressure to the taped area. Pressure that is less than 15lbs.(49N) may allow the tape to peel , creating gaps.**
- f) Remove **templates A LH (E), B LH (F) and C LH (G).**
- g) Repeat operation for opposite side using molding (C) and (D) and templates (H), (I), and (J)